

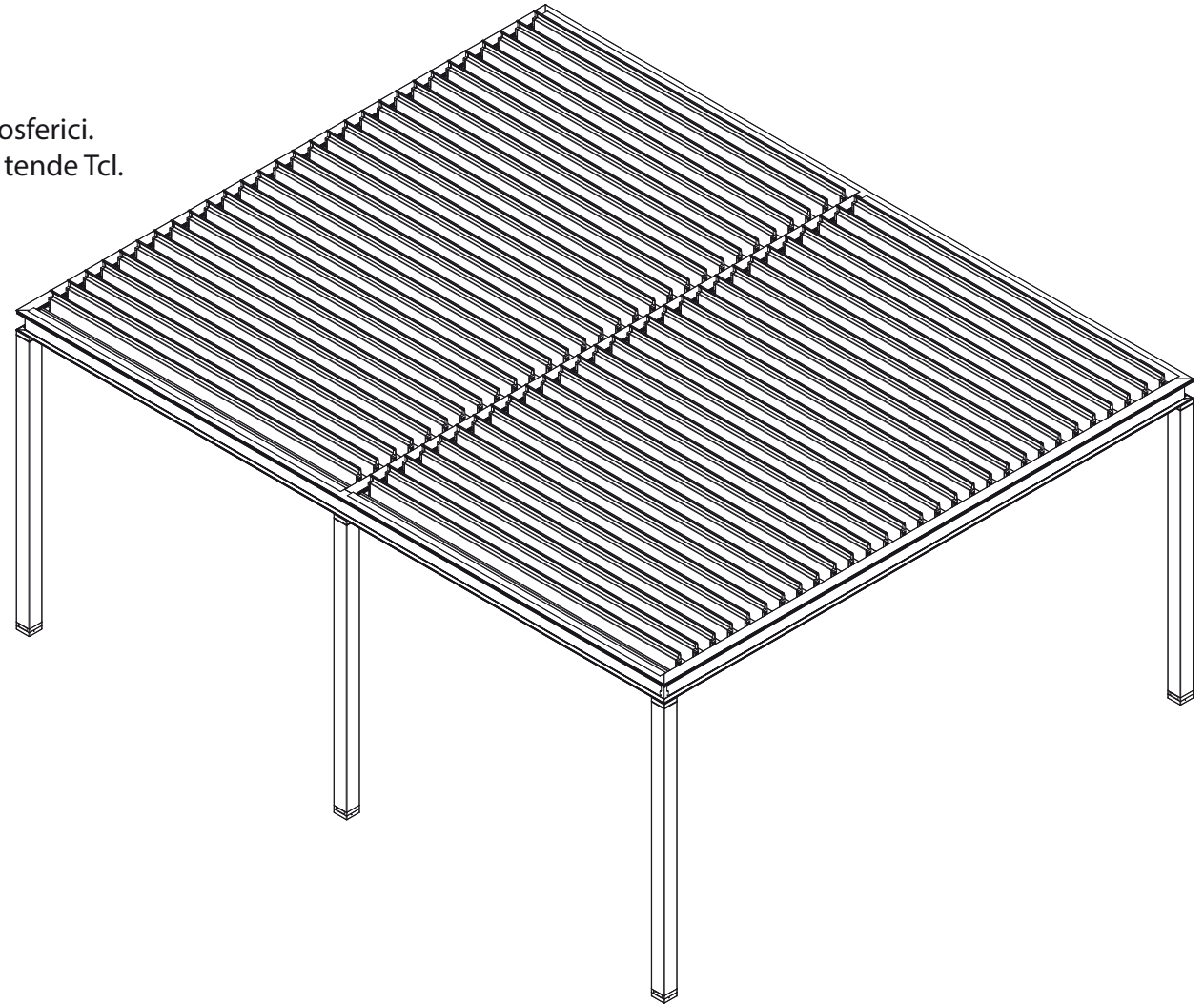

- Struttura in alluminio colori Bianco (9010), Avorio (1013), Marrone (8017) e Antracite (DR-703).
- Lamelle in alluminio verniciato da 180,9 mm. Per larghezze fino a 300 cm
- Lamelle in alluminio verniciato da 186,5 mm. Per larghezze fino a 400 cm
- Orientamento lamelle da 0° a 90°.
- movimentazione doppio motore con telecomando (di serie)
- Pendenza minima per il deflusso dell'acqua 5%.
- Resistenza al vento classe 4.
- Scarico dell'acqua all'interno delle gambe.
- Protezione dalla pioggia, dal sole e alta resistenza agli agenti atmosferici.
- Possibilità di realizzare coperture modulari e di chiudere i lati con tende TcI.
- Attacco a parete; altezza gambe cm 230.

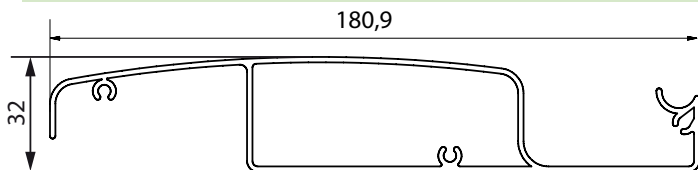

Lamella fino 300 cm



Lamella per larghezze superiori a 300 cm

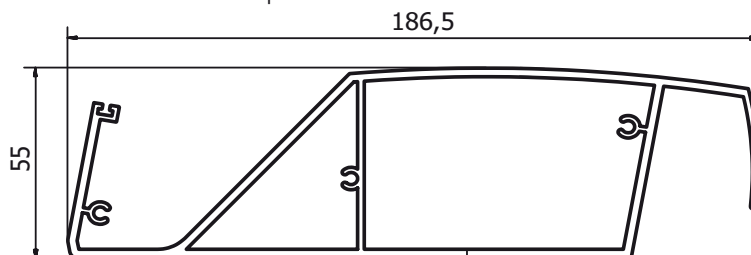

PROFILO GUIDA

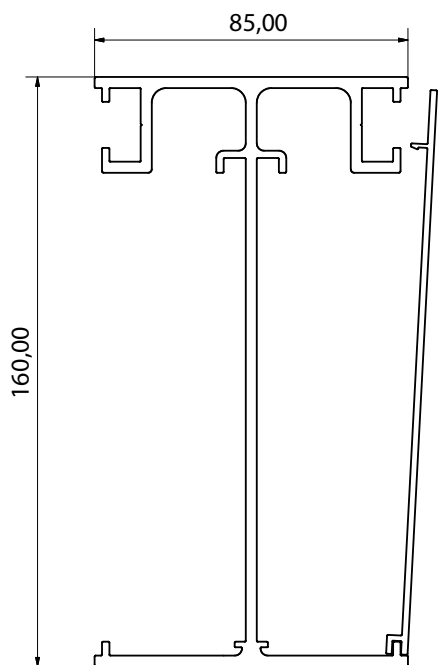

PROFILO GRONDA

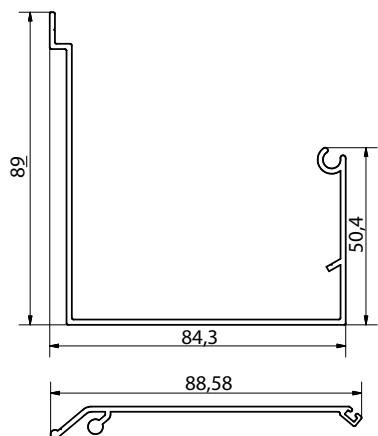

PROFILO COMPENSATORE

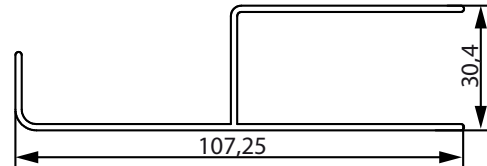

PROFILO
ASTINA



Staffa angolare optional consigliata sulle autoportanti dove non sono presenti TCL perimetrali o vetrate

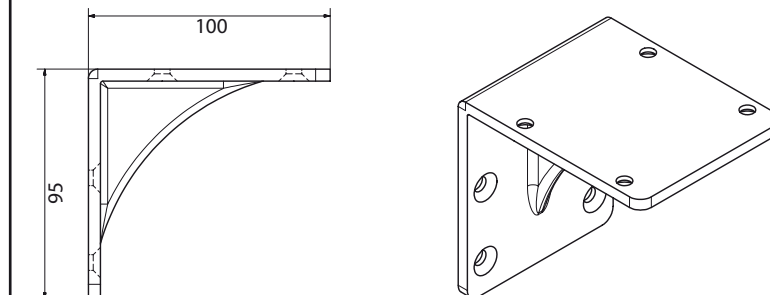

GAMBA

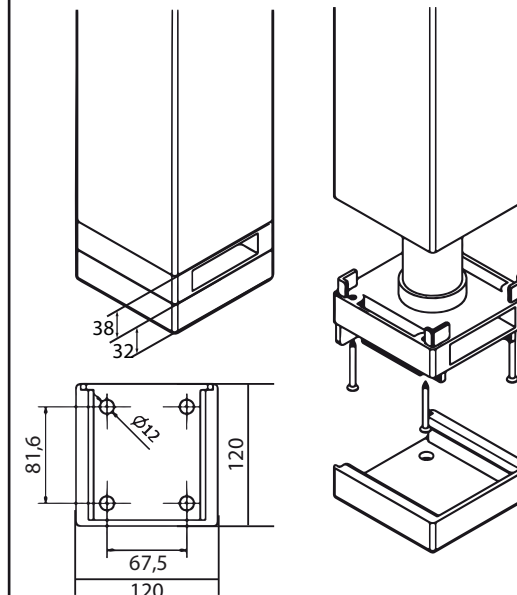

Staffe Frangisole
addossata

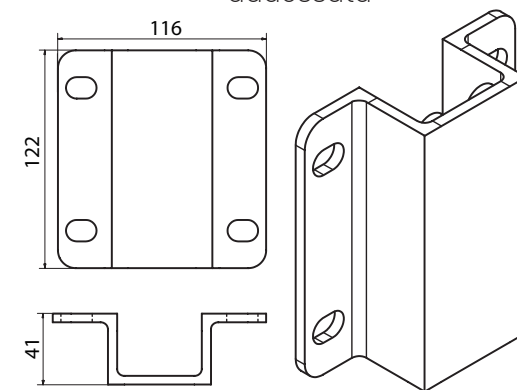

Ingombro lamelle aperte

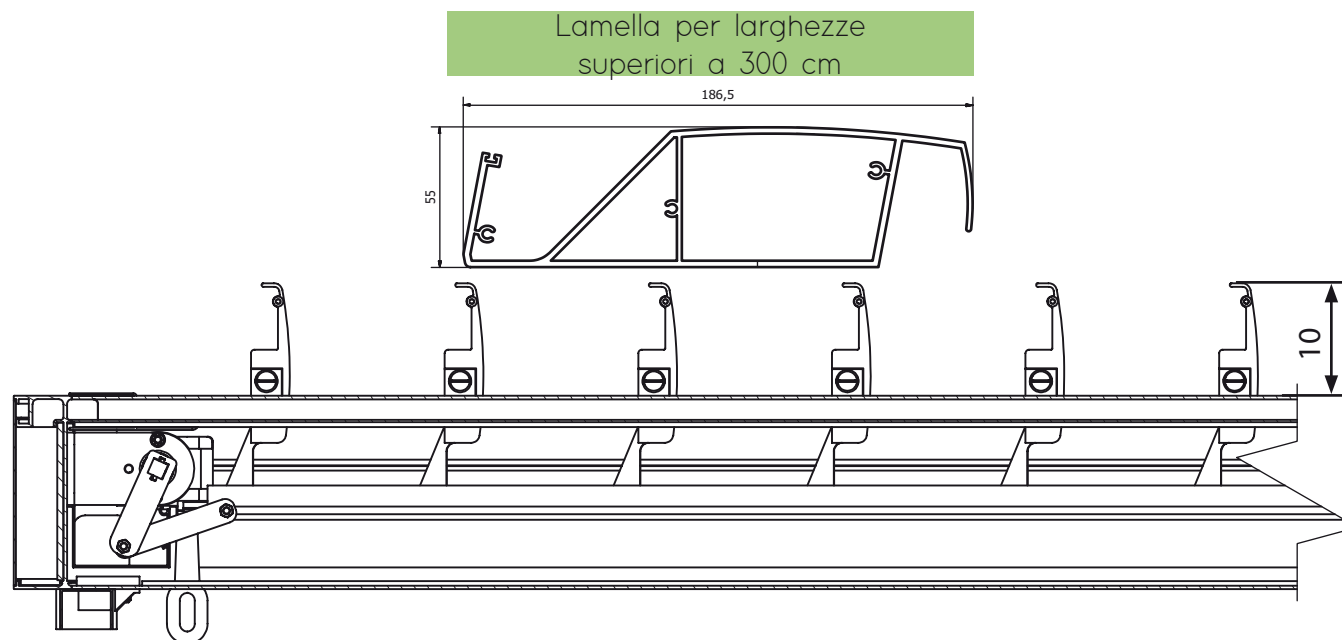
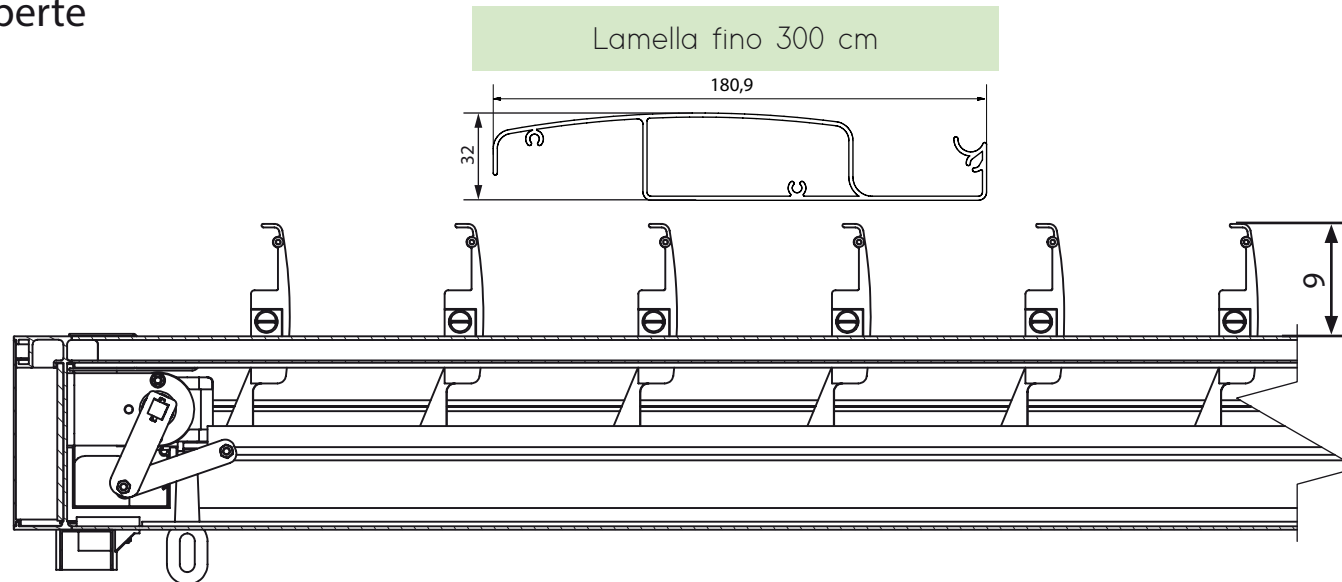



Manovra arganello

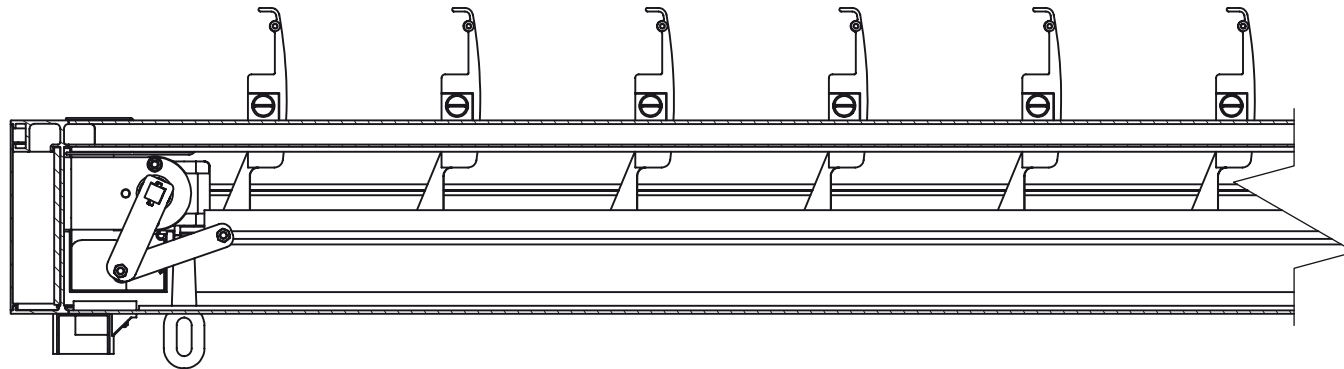

Manovra motore

